



# CURTAIN WALL INSTALLATION GUIDE

# IMPORTANT NOTICES & INFORMATION

The building envelope must be correctly prepared with weather resistant barriers – that meet local and state codes. All frame and sill surfaces must be correctly prepared for air, water, and structural integrity by the builder or contractor before attempting installation. In order to meet warranty requirements, all systems are required to be installed by a certified installer.

- Loewen is not responsible for site measurements nor the structural and architectural requirements for the installation of the Curtain Wall.
- Building design, construction methods, building materials and site conditions unique to your project may require methods different from these instructions.
- Choosing the appropriate method is the responsibility of you, your architect, or your construction professional.
- Confirm with sealant/foam/barrier manufacturers that all materials used are compatible with one another.
- Any local, regional or national building code requirements supersede these instructions.
- Safety is top priority for Loewen. Use proper work procedures and protective equipment.

## Site Preparation Advisory

This manual is intended for construction professionals with proven competency installing doors and windows for large openings. Curtain Wall installations are complex and should not be attempted with simple written documentation.

## Pre-Installation Site Check

You must work from the provided drawings to prepare the opening.

- The rough opening is the correct size, plumb and square.
- Verify that the concrete or sub-floor where the system is to be installed is level. The frame system may be shimmed to compensate for an uneven floor but will adjust the relationship of the systems sill to the finished floor and may increase the overall height of the system in the opening. Any serious deflection in the concrete or sub-floor where the system is to be installed must be corrected prior to installation.
- It is important that your framer knows the finished floor thickness to determine the header height.
- The level of the finish floor needs to be determined ahead of time and noted somewhere near the opening.
- Exterior surface must have a negative slope from the sill assembly to allow water run-off from weep system (Recommend 2 degrees).

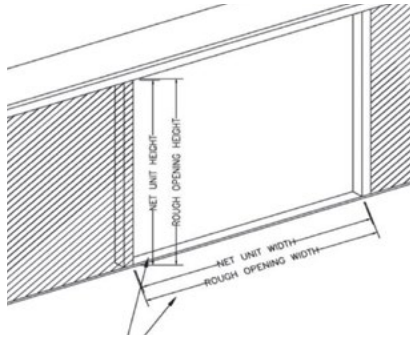

Verify unit and rough opening dimensions match drawing provided

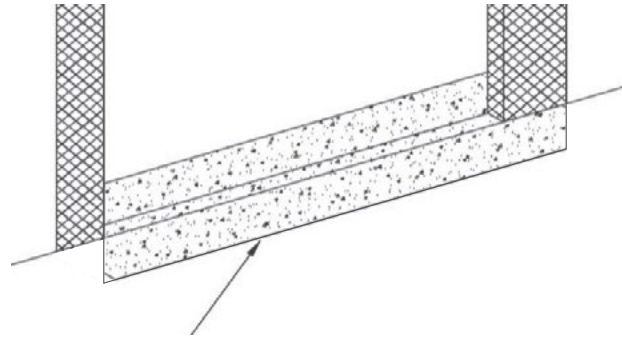

Sill pans must be used in every installation of a Curtain Wall System

### Tools Required

- Laser Level
- Hammer
- Pry Bars
- Ladders
- Utility Knife
- Screw Gun
- Applicator Foam Gun
- 'J' Roller
- Tape Measure
- Caulk Gun

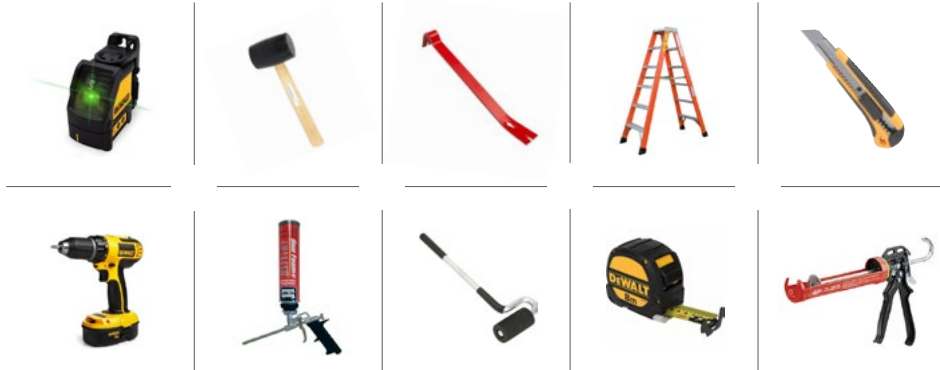

### Materials Provided

- Nail-Screws (VARIES)
- Transom Profile Sealing Piece (VARIES)
- Cross Point Sealing Plate
- Transom Pressure Profile Sealing Piece (VARIES)
- Pressure Profile Screw (VARIES)
- Provided Shims
- Temporary Pressure Plates
- Sealant

Note: Typical example, will vary by project

### Curtain Wall Install Kit

- Interior Gasket Roller (109502)
- Cover Removal Tool (109503)
- Torx T20 Driver Bit (108711)
- Torx T25 Driver Bit (109443)
- Torque Wrench 1/4" Drive (107009)
- Torx T20 Socket Bit 1/4" Drive (109446)
- Torx T25 Socket Bit 1/4" Drive (109447)
- Hex 3mm Socket Bit 1/4" Drive (109448)
- Hex 5mm Socket Bit 1/4" Drive (109449)
- Punch Tool (83145)

10CWKSTOREA (available in parts catalogue)



## Sill Pans & Weather-Resistant Barriers

- Sill pans can be rigid or flexible and are required to be used in all installations, sill pans are supplied by the contractor/builder.
- Pan flashing is used at the base of openings and designed to collect and drain water directly to the exterior or onto the weather resistive barrier.
- Sill pans should be slightly sloped outward with a minimum 6" end dam, 1/2" interior upturn leg and 2" exterior down turn leg.
- Before fastening the rigid sill pan, apply three heavy 3/8" rounded bead of OSI TeQ Seal onto the construction plate, on the outboard, inboard and at the exterior down turned leg. Continue the sealant approx. 6" up both jambs at each end.
- Set the pan into the sealant and check for level. Secure the end dams with fasteners as required.
- Seal the end dams with sealant; tool the end dams to the framing.
- All installations must have a weather resistant barrier. WRB should be applied and/or fastened per manufactures instructions.
- If WRB wrap is applied then cut away with a complete box cutof the opening.
- No WRB should be brought into the rough opening.
- Cut back and expose the sheathing at the side jambs by removing approximately 1 1/2" of WRB. This will create direct-contact seal to the sheathing for flashing.
- Flash the opening jambs and head with OSI TeQ Flash™ before installation.
- Ensure that the flashing and the sill pans are properly overlapped and remain water resistant.

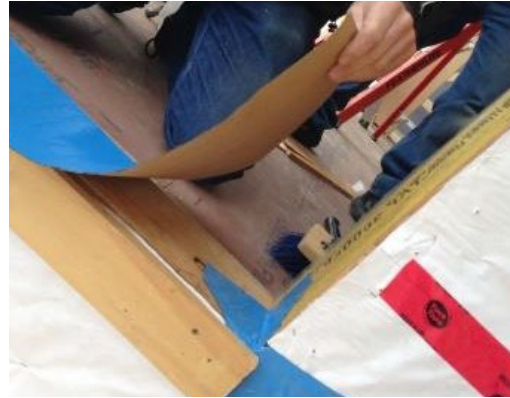

## Crates

1. Open crates by removing screws located along the top lid.
2. Check for instructions, drawings, and parts inside the crates.

### Parts included in the crate:

- Transom and mullion timber with base profiles and gaskets
  - Transom and mullion pressure profile with gaskets
  - Transom and mullion compensation blocks
3. CW Install Kits are sent separately and should be checked by installer

### Important Notes:

- Every CW has compensation blocks along the perimeter of the unit and around inserted windows and doors. Always remove compensation blocks on transoms as well as around doors/windows (if any) prior to installing.
- Always pull back both edges of the rubber gasket on horizontal transom members before sliding into brackets.
- Any unfastened screw holes must be filled with sealant to avoid water infiltration.
- Always slide in the transom straight and equal on both sides.
- Always fasten the screws straight and perpendicular.
- Use the correct torque to fasten the aluminum screws and screw-nails.
  - Glass carrier torque: 71 inch-pound.
  - Pressure plate torque: 40 inch-pound.



# ROUGH OPENING SIZE DETAIL

**The building's rough opening must not be undersized.**

The rough opening dimension stated in Loewen's documentation (example shown here) is the bracket-to-bracket dimension of the curtain wall. The building's rough opening can be slightly oversized as per industry norms, however the rough opening MUST NOT be undersized.

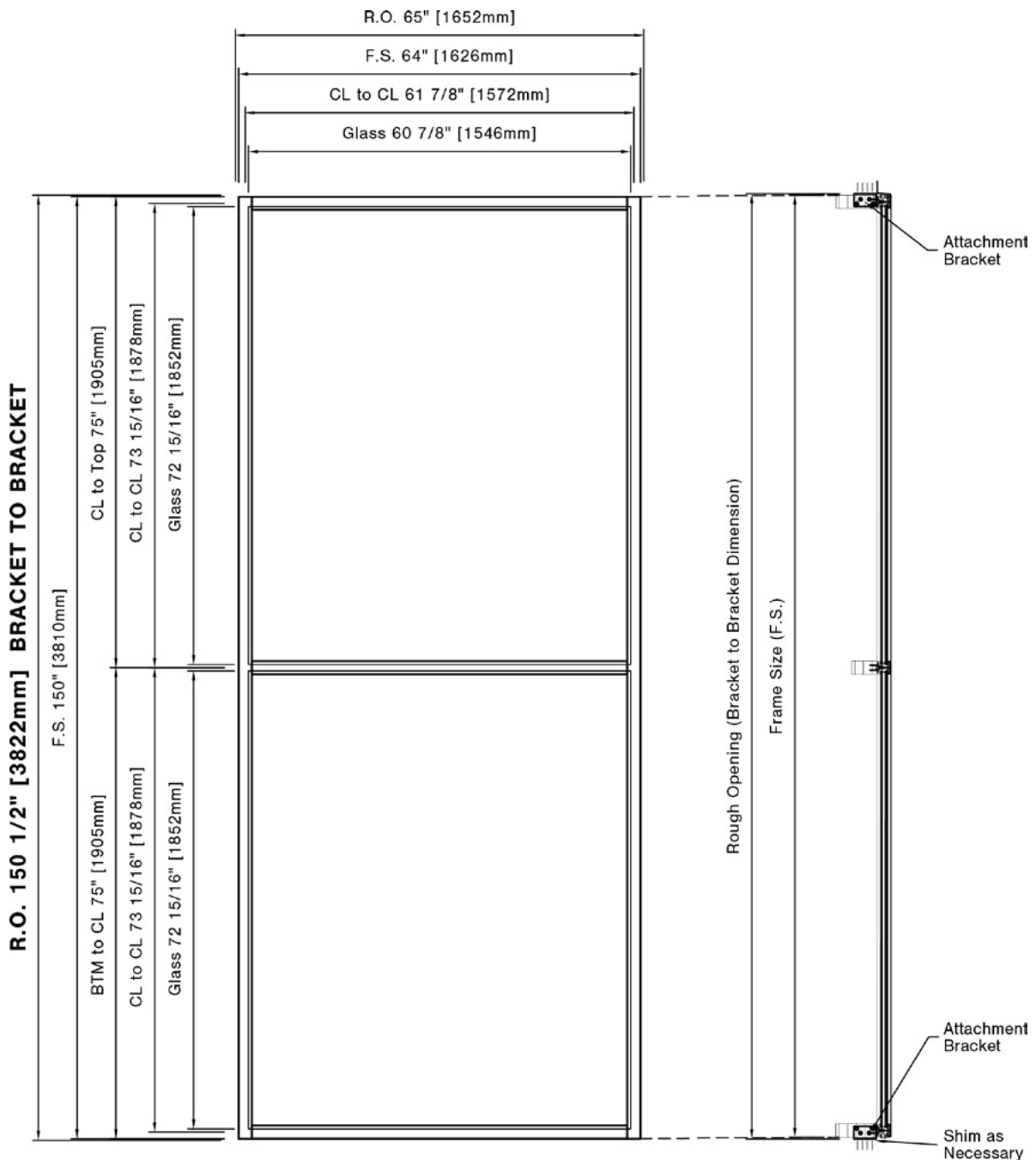

# ROUGH OPENING CLEARANCE DETAIL

Please review the curtain walls relationship to the surrounding structure.

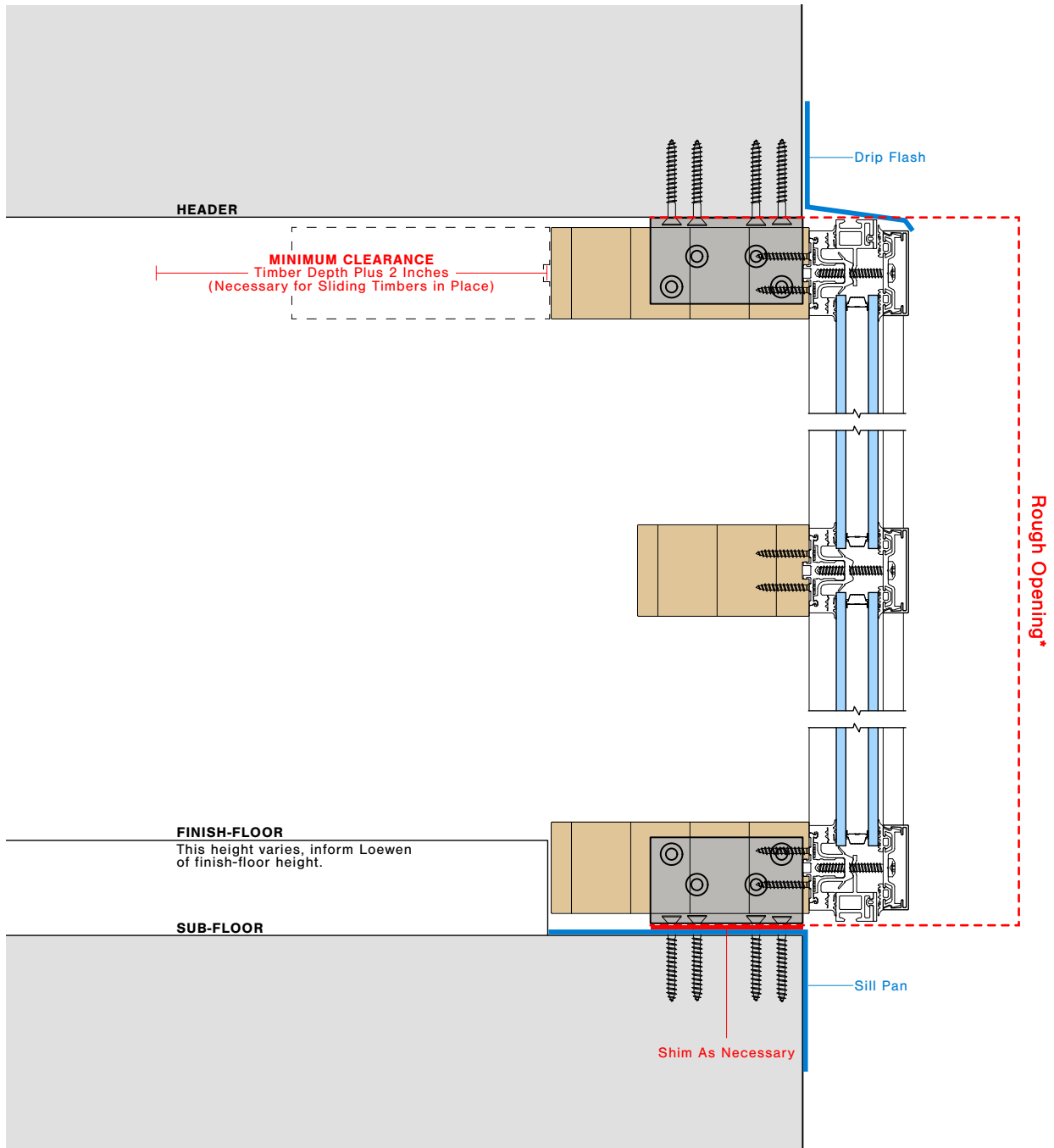

\*As stated on the previous page, the rough opening dimension stated in Loewen's documentation is the bracket-to-bracket dimension of the curtain wall. The building's rough opening can be slightly oversized as per industry norms, however the rough opening **MUST NOT** be undersized.

# SEALANT WARNINGS

**Curtain Wall weeping systems must not be obstructed.**

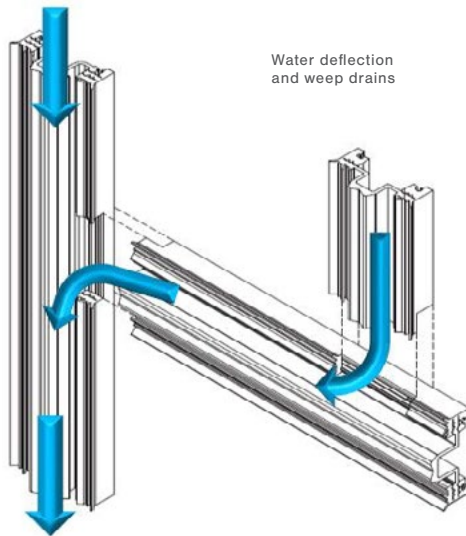
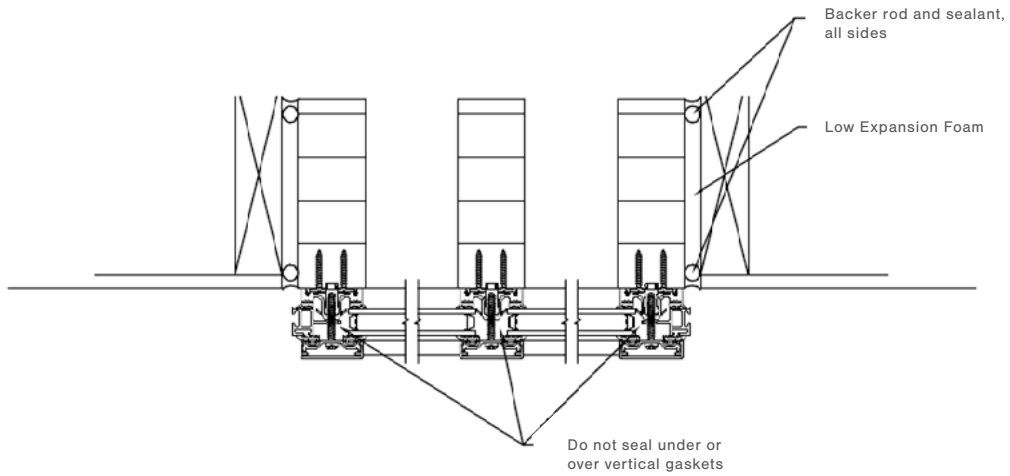

Sealant or other barriers must not obstruct the ability of the vertical members to drain or ventilate. Do not apply sealant to head or sill of vertical gaskets and covers.



## Preparation

1. Check the rough opening to ensure it matches drawing specifications.
2. Set a laser to make sure the floor is level. Shim as required.
3. Check with the general contractor where to start the height of the sill for finished floor level.
4. Installation typically starts with a vertical mullion at one end of the curtain wall assembly; (If the unit has a corner, start at the corner).
5. Following the shop drawing set the floor bracket flush with the outside wall.  
**Note:** The gasket rubber attached to the vertical mullion must be outside of the rough opening for standard drainage.
6. Once in place and plumb, snap a line flush with the interior of the curtain wall to the other end of the rough opening. Make sure the distance between the line and the outside wall is consistent on both sides.



Step 1-5



Step 1-6

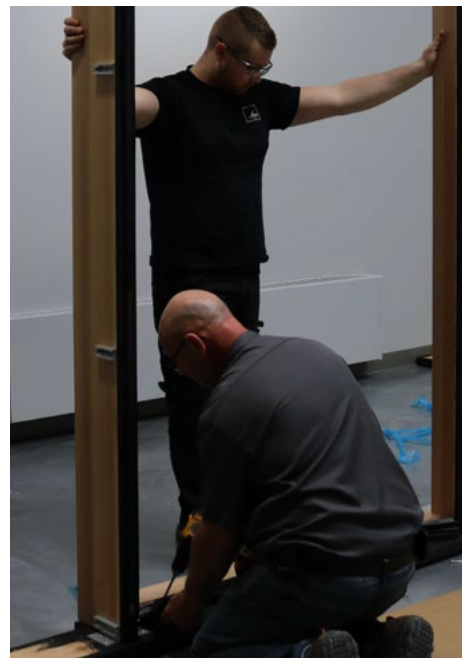

## Structure Install

1. Once the first mullion (or corner piece) is in place and plumb level, fasten the bracket using either flathead or concrete screws (depending on surface) straight into the bracket holes.
2. Remove the compensation block on the bottom transom to ease installation of horizontal members.
3. Place next the mullion along the snap line and slide the bottom transom partially in between the two vertical mullions, leaving 2 of the 4 bracket screws available for screw installation on the free mullion.

**Note:** Pull back the rubber gasket on the edges of the transom to clear the TC connector.

4. Clamp (if possible) mullions together at the bottom to hold the free mullion in square position and ensure tight fit and no gapping.
5. Install screws into the available holes on both sides of the interior brackets of the mullions.
6. Remove any clamps and then remove the transom to access remaining brackets holes
7. Apply screws in the remaining holes in the brackets.
8. Holding back the rubber gasket on ends of transoms, slide transom in until fully seated with the exterior face flush with the mullion.



Step 2-1



Step 2-2



Step 2-3A



Step 2-3B

**Structure Install (Continued)**

9. TC connectors transom on each will now be accessible. Nail-screws (aluminum) are used to lock the vertical and horizontal members together.  
**Note:** If Timber is 300mm, drop pin into TC connector, use punch to get to correct depth before putting in nail-screw
10. Nail-screws should be at least 1" shorter than transom or mullion.
11. Insert the appropriate length nail-screws into the holes and fasten snug. (Do not over tighten)
12. Remove tape backing and insert the transom profile sealing piece into the rubber gasket.
13. On the rubber gasket connection edges, trace with a small bead of sealant to ensure seal integrity.
14. Using the 'J' roller tool provided, roll the rubber gasket securely back into place. Check that transom gasket is fully seated and in direct contact with the mullion gasket.
15. Steps 9-14 should be repeated on the top transom of this section, then complete all transoms between the mullions.
16. Repeat steps 1-15 for the next vertical sections of the curtain wall structure. Place one mullion at a time and fill in all the transoms before moving on to the next mullion.



Step 2-11

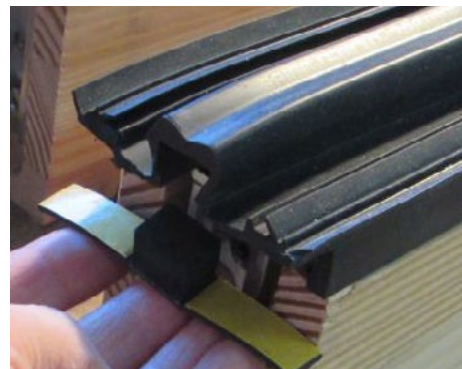

Step 2-12

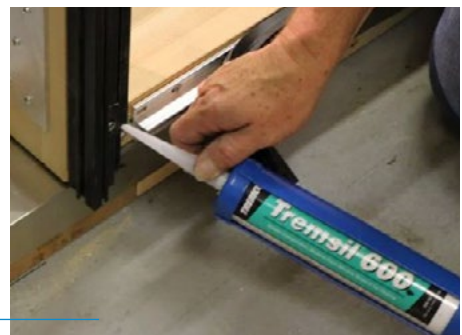

Step 2-13

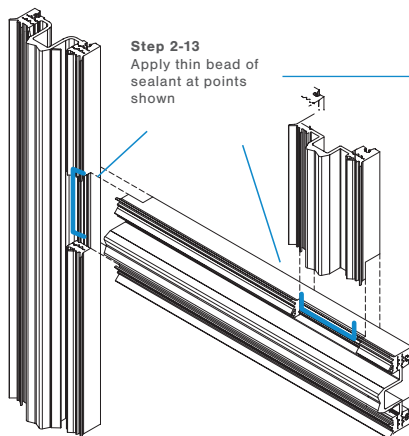

Step 2-14

## Glass Install

1. Ensure all corner gaskets are correctly seated and flat.  
Note: Glass is installed from bottom to top of each section.
2. Replace any compensation blocks that were removed earlier, using the same holes previously used. If this is not possible for ANY reason, ensure that all unused holes through gasket are filled with sealant.
3. Place a provided composite shim on each of the glass carrier pads purposely leaving the shim twisted out slightly for access once the glass is in place.
4. Place the glass panel onto the bottom transom shims, and ensure the glass is seated against the rubber gaskets.  
**Note:** Place the shim slightly off of perpendicular to the face of the transom
5. Once glass is seated, push the shims in until flush with the glass face.
6. Fasten the small temporary pressure plates at a vertical mid-point of the glass panel, using the pressure plate screws provided.
7. Screw in to the aluminum "V-Dent" located at the center of the rubber gasket.
8. Continue with the next vertical glass panel above first panel using steps 2 to 7 above.
9. Once all vertical panels are completed fasten small temporary pressure plate between each panel and at the top and bottom of the section.
10. Apply the adhesive cross point sealing plates onto the glass at every corner. Check the placement from the interior to ensure that from the interior you won't see any silver line peeking into the visible glass area.



Step 3-4



Step 3-5

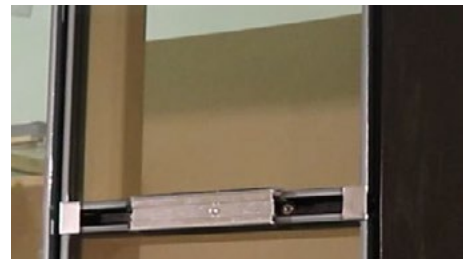

Step 3-6



Step 3-10

Step 3-7  
Screw into the "V-Dent"  
through the center of the  
rubber gasket.

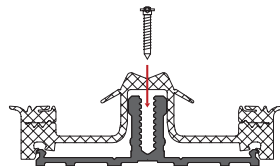

## Glass Install (Continued)

**11.** Remove the temporary pressure plates from the first vertical side fill the holes left in the rubber with sealant.

**12.** Install a full length permanent pressure plate, with the ventilation hole at the top of vertical mullion. The pressure plates is set at least 1/8" above the bottom of the compensation blocks to allow correct drainage of system.

**13.** All pressure plate screws should be installed loosely to allow proper torque pressure in next steps.

**Tip:** Power drill/drivers can be used in this step only if set to a very low setting, then use the torque wrench to finish.

**14.** Repeat steps 1 to 13 for the other mullion sections.

**15.** Finish the exterior with the final vertical pressure plates and then apply all the horizontal pressure plates.

**Note:** Vertical and horizontal rubber edges should perfectly butt up to each other, not overlapping.

**16.** If the gaskets on the horizontal pressure plates do not sit flush or overlap, they will need to be trimmed for a proper fit and seal.

**17.** All pressure plates will now need to be tightened to the correct setting. Secure all the pressure plate screws to 40 inch/pound using the CW Kit torque wrench.

**18.** Start at the center of each vertical and work your way to the end of the plate (All horizontal pressure plates must be in place before tightening).

**Note:** Make sure the rubber fins on the pressure plates do not fold over or in when tightening

**19.** Once all the pressure plates are on and secure the finishing exterior metal covers can be applied. Start with the verticals and complete both sides of a section before applying the horizontals. See next page for fastening plate details.

**20.** Apply metal covers to pressure plates by placing one side into location and pressing or gently tapping until cover clicks into place.

**Note:**Horizontal covers are provided longer than required. To ensure ideal fit and finish the installer will need to measure opening and then trim the horizontal covers to the correct length.



Step 3-15



Step 3-17



Step 3-20

## Fastening Plates

1. A Fastening Plate should be applied on all the lowest pressure plate transoms (see drawings)



\*Fastening Plate

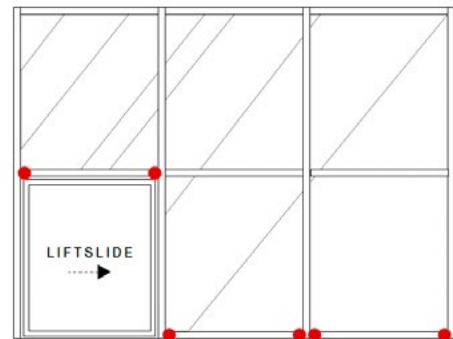
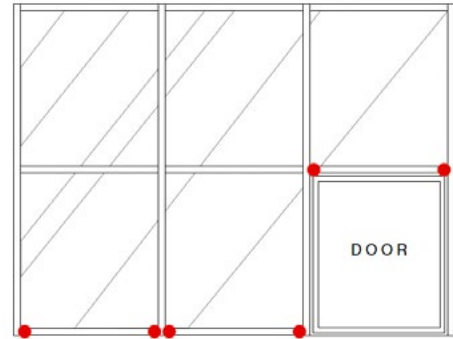

\*Red indicates Fastening Plates

2. With the flat side of the Fastening Plate against the vertical metal cover, use the guide hole to pre-drill with a 3mm bit.

**\*\*Using another size of bit will compromise the amount of grabbing force\*\***

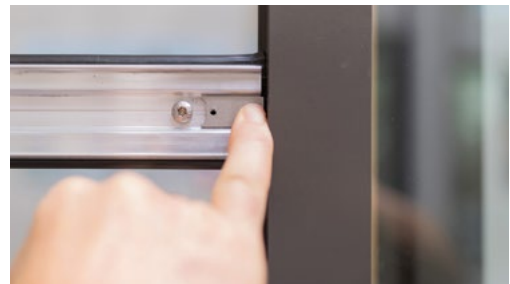

3. Rotate the Fastening Plate 180 degrees, apply a 3.9x13mm screw through the pre-drilled hole from step 2.

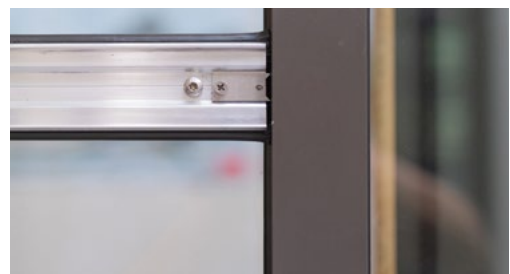

# HINGE SHIM & ANCHOR GUIDE FOR TERRACE & FRENCH DOORS

## Supplement Installation Instructions

These supplemental instructions describe how to properly install Terrace & French Doors.

### Parts:

- Anchor Block (provided)
- #10 x 1 screws (Part # 83903)
- #2 x 2 screws (provided) or
- #8 x 2 screws (provided)

1. Hold anchor block (provided) in place on hinge-side mullion, starting from the bottom. Pre-drill holes using a 3/16" diameter bit through the anchor block (holes should be larger rather than smaller to avoid cracking). Holes should be 50- 200mm from each end. Be sure to avoid conflicts with belay sheet or pressure plate screws.
2. Install anchor block with 83318 screws (provided) at both ends.
3. Repeat steps 1 and 2 with additional pieces towards top of door opening. Place anchor blocks together with no gaps. Final piece may require cutting to size.

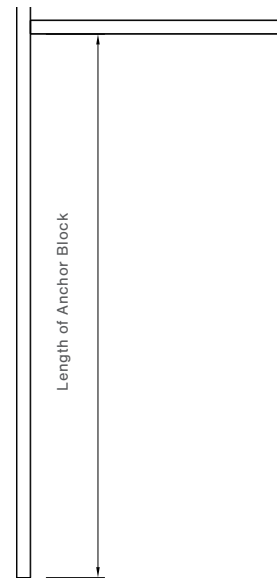

Pre-drill anchor block  
3/16" for #10 x 1 screw

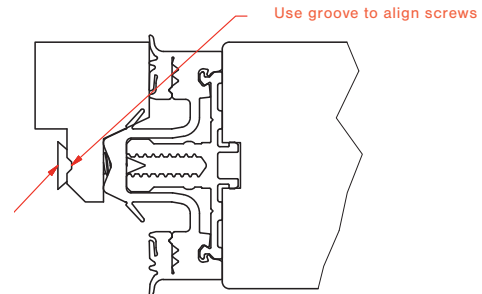

4. Install and set the door unit plumb, level, and square into the rough opening. Ensure that framing shims have been placed between the jamb and the stud directly behind hinge locations.
5. Apply crosspoint sealing plate as shown earlier in this guide.
6. Place pressure plate in place and pre-drill holes using 3/16" diameter bit through anchor block. Apply pressure plate and cover profile as shown earlier in this guide.

7. Remove the odd coloured screws from the hinge leaves on the frame side and replace with the hinge coloured screws. (2 in the top/bottom hinges, 1 screw in the middle hinges)
8. Pre-drill the open holes with a 5/32" bit to about 2" depth from hinge face.
9. Drive #12 x 2" screws (provided) into the pre-drilled holes from step 8. (Adjustable hinges require #8 x 2" screws)
10. Check the lock side of the door to ensure that the multi-point system operates smoothly and that the panel has enough clearance to swing without interference.
11. If the lock side of the door is too tight, remove the shim from behind the panel mounted leaf (factory installed) of each hinge. Loosen screws of one hinge leaf, remove shim, and then tighten screws before moving to the next hinge.
12. If the lock side is still too tight, remove shim from behind the frame mounted leaf (factory installed) of each hinge in the same order as in step 6.
13. If the lock side of the door is too loose, add one shim (provided) to the panel mounted leaf of each hinge. Loosen screws of one hinge leaf, add shim, and then tighten screws before moving to the next hinge.

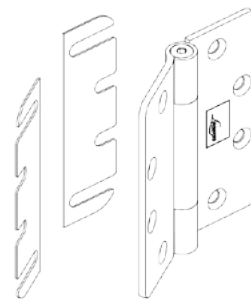
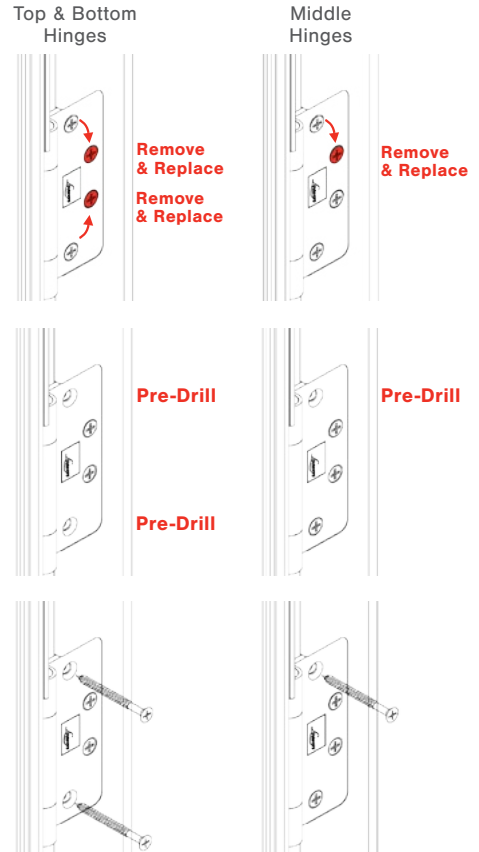



# DRAWINGS OF TOP METAL CAP FOR LIFTSLIDES IN CURTAIN WALL

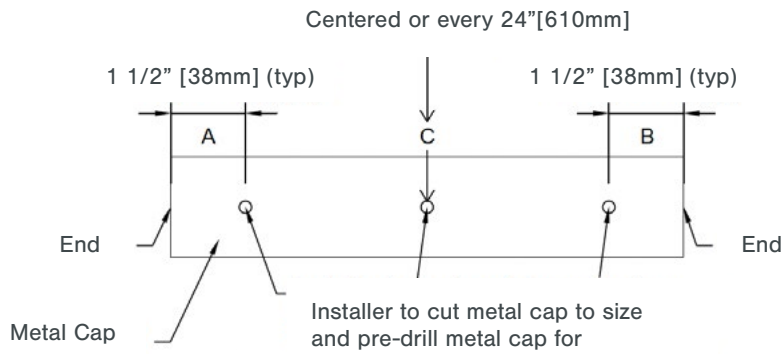
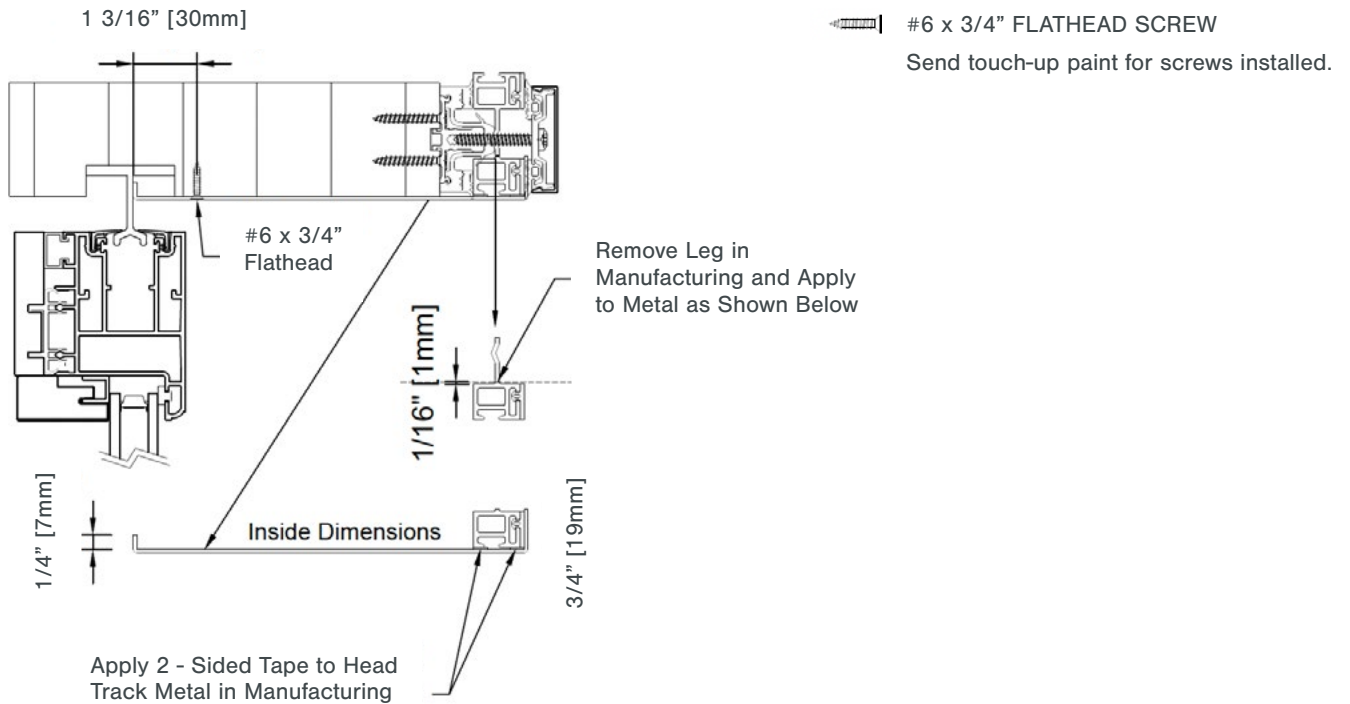

#6 x 3/4" 318333 flathead screws

Information subject to change without notice.

Distributed by Loewen Inc. in the USA and C.P. Loewen Enterprises Ltd. in Canada and internationally. Trade Marks owned by C.P. Loewen Enterprises Ltd. Used under license.  
© C.P. Loewen Enterprises Ltd. All rights reserved.  
P3153A-09-23

The Loewen logo is displayed in a red rectangular box. The word "Loewen" is written in a white, elegant, cursive script font.

[LOEWEN.COM](http://LOEWEN.COM)